

## Spectroscopic studies of laser generated plasma X-rays and their effects on polymeric materials

Muhammad Bilal Tahir\*, Shoaib Ullah, Safdar Ali, M Rafique & M S Rafique

Department of Physics, University of Gujrat, Gujrat, Pakistan

*Received 24 June 2017; accepted 3 November 2017*

Surface modification of polymers by X-rays produced from laser plasma can put a wide range of changes and are magnificently used in effectively all industries ranging from coatings, semiconductors, household appliances, automotive, and biomedical implants. Polymeric materials commonly have outstanding bulk physical and chemical properties. Different properties like electrical, chemical and physical properties can be modify when an extreme dose of X-rays is exposed on the surface of polymers. Currently X-rays are irradiated on the surface of two different polymers including polypropylene and polyethylene. These X-rays are detected with pin photodiode (BPX-65), generated from laser generated Cu plasma where Nd: YAG laser (1064 nm, 10 mJ) is focused on copper. Polymer surface is exposed to X-rays by different shots of laser which are varied from 100 to 400 with a gap of 100. Morphological structure has been studied by using optical microscopy and four point probes are used for studying the resistivity and conductivity. It has been observed that irradiation of X-rays from laser produced plasma produce changes in the bonding structure of polymers due to cross linking and chain-seasoning which are highly responsible for breakage or formation of a bond. A similar type of a result is deduced from four-point probe method that the resistivity of polymers is decreased due to the breakage of the H-C bond.

**Keywords:** Coatings, X-rays irradiation, Polyethylene, Cross linking, Polymers

### 1 Introduction

Polymeric materials have been applied efficaciously in fields like biomaterials, adhesion, protective coatings, composites, friction and wear, microelectronic devices, and thin-film technology<sup>1-5</sup>. In general, special surface properties with regard to chemical composition, roughness, hydrophilicity, conductivity, cross-linking density, crystallinity, and lubricity are required for the success of this applications<sup>6-8</sup>. Photons of the soft X-ray spectral region ( $\approx 0.1-10$  nm) have very small absorption lengths in all kinds of material due to the strong interaction with matter. This fact together with the short wavelength qualifies this radiation as a tool for structuring and the analysis with nanometer resolution<sup>9,10</sup>.

Polymers very often do not own the surface properties desirable for such kind of applications. However, they have admirable bulk physical and chemical properties, inexpensive and easy to process<sup>11-13</sup>. For these reasons, surface modification techniques which can alter these economical materials into highly valuable finished products have become an important part of the plastics and many other industries<sup>14-17</sup>. In recent years, many advances have been made in

developing surface treatments to alter the chemical and physical properties of polymer surfaces without affecting bulk properties. Common surface modification techniques include treatments by flame, corona, plasmas, photons, electron beams, ion beams, X-rays, and  $\gamma$ -rays<sup>18-22</sup>. X-rays are used for various analytical techniques, e.g., for X-ray photoelectron spectroscopy, electron spectroscopy for chemical analysis, and extended X-ray absorption fine structure<sup>23-26</sup>. The ion and X-ray implantation find successfully their applications in optical, microelectronics and optoelectronics fields. The changes in different physical properties make these polymers best for lithography and assembling of a lot of devices in optics. These modified polymers also fit their applications in medical and cosmetics where we can fabricate different conducting and non-conducting devices as well<sup>27-29</sup>.

The current experimental work is also a step to investigate the different surface properties of polymers like polypropylene and polyethylene. These polymers are modified by X-rays produced from laser plasma to meet the required goal. The characterization techniques like optical microscopy and four point probe method have been used to study the after effects of irradiation on these polymers.

\*Corresponding author (E-mail: m.bilaltahir@uog.edu.pk)

## 2 Experimental Details

This experiment is performed in two steps. In the first step laser generated X-ray signals are detected with the help of digital storage oscilloscope for the calculation of energy, and then in the second step substrates (polyethylene and polypropylene) are exposed to X-rays from laser produced plasma. All of this experiment is performed in a vacuum in  $10^{-3}$  torr.

### 2.1 X-rays emission and detection

In the first part of the experiment X-rays are being detected by a pin photodiode in a vacuum. In this portion of the experiment, the setup is arranged such that the target is placed inside the vacuum chamber made up of pure steel at  $45^\circ$  to laser and  $90^\circ$  to pin photodiode (BPX-65) filtered with aluminum of thickness 10 micron having spectral range of 350 nm to 1100 nm wavelength. Pin photodiode is connected to the digital oscilloscope with a biasing circuit as shown in Fig. 1. Vacuum chamber is connected to rotary vane pump through the diffusion pump to create a vacuum of  $10^{-3}$  torr. This vacuum is created almost in three hours. To achieve compact pulsed X-ray sources the following method is currently used; a pulsed laser beam hits target material in a target and creates plasma.

The interaction of the plasma with the laser beam excites the electrons and creates hot electrons. The interaction of the hot electrons with the target material yields the X-ray emission. The target material is deteriorated by the high energy of the laser beam;

usually the target material is evaporated at the position where the laser beam hits the target material. The target can be moved to cope with the problem of the deterioration of the target material and accordingly each pulse of the laser beam hits new target material. The movement can be achieved by rotating targets, wire targets or by so-called band targets.

The laser is focused through a focusing lens of 20 cm focal length. When laser is focused on target copper, plasma will be created as a result of laser matter interaction. The main focus of the experiment is on the emission of X-rays which are being emitted from the laser produced plasma. These rays are detected by removing the TO-18 window of BPX-65 Pin Photodiode. This pin photodiode is operated with the voltage of 46-50 V. The resulting signals of X-rays are stored with the help of digital storage oscilloscope. The schematic diagram of this experimental part is shown in Fig. 2.

### 2.2 Irradiation of polymeric materials

In order to expose substrates (PE and polypropylene) with X-rays produced from laser produced plasma with Nd: YAG Laser, copper target is placed at right angle to substrate and laser is placed at  $45^\circ$  to the copper target. Infrared lens is used to focus the laser at copper. The schematic diagram of the experiment is shown in Fig. 3 below.

The distance between the target and substrate is 1 cm and the focusing lens used in front of the laser has a focal length of 20 cm. In this way, pure X-ray

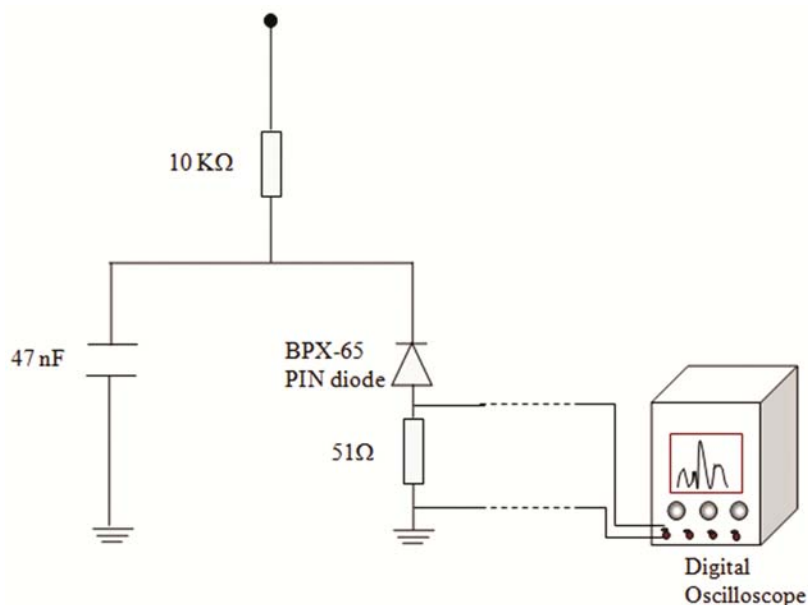

Fig. 1 — Biasing circuit for X-ray detection.

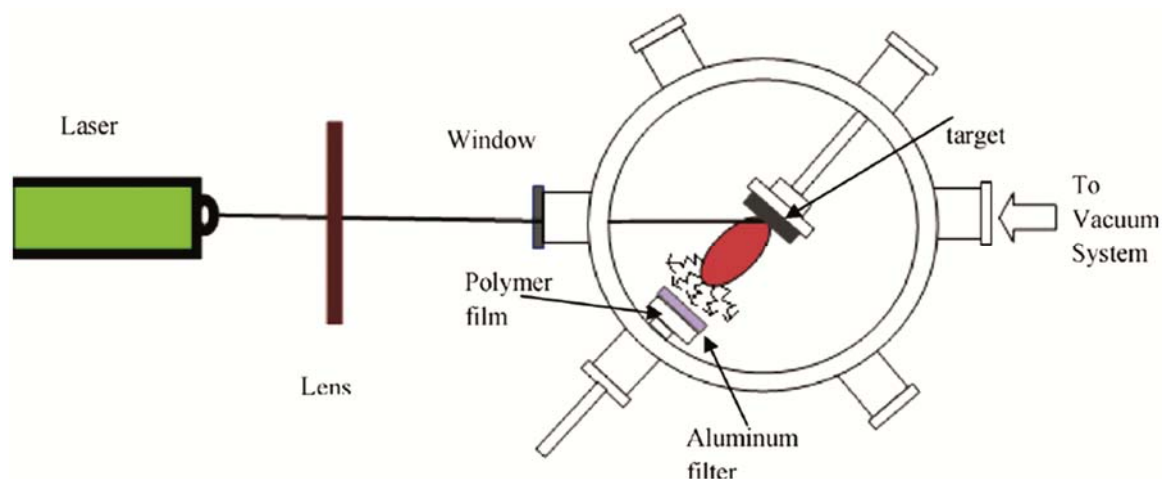

Fig. 2 — Schematic diagram of experimental setup.

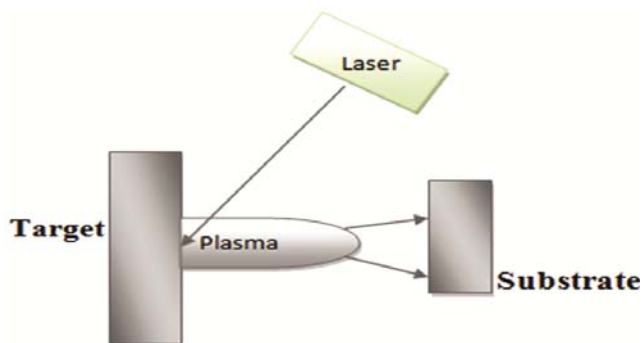

Fig. 3 — Schematic diagram of experiment.

interaction with polymers is being studied. Polymer samples are filtered with the aluminum sheet of 10 micron thickness. Samples of PE and polypropylene are exposed with the different number of shots and then characterized which will be discussed in later part.

### 3 Results and Discussion

When Cu target is irradiated with laser beam then the breakdown of surface molecules occurs as energy is absorbed by the target atoms. This produces electrons which move away as they are of lower energy by leaving holes, therefore creating an electric field. An attractive force between ions and electrons then slows down the electrons producing three different interesting phenomena:

- i. The electrons lose energy while passing near the ions producing Bremsstrahlung radiations or X-rays.
- ii. Electrons are recombined with ions producing X-rays.
- iii. A bound electron jumps lower energy state by losing its energy creating a discrete set of energy.

X-rays generated by all three means which are mentioned above are typically dependent over formation strategy of plasma. If the atomic number of metal increases, then line emission is strongly dominated while for higher atomic number the Bremsstrahlung emission is possible. As the atomic number changes lasting time for X-rays signal is increased. This is all due to duration of produced plasma. Larger atomic number targets produce stronger electric field, as in this case nucleus becomes more positive. Therefore, plasma produces for longer time which results higher energy and intensity X-rays emitted.

The typical time resolved X-ray signal profile generated from Cu (29) is shown in the Fig. 4. It has been observed that at the start of the signal, there is a small disturbance which indicates the production of plasma with the emission of only few X-rays due to bound-bound transition. As the time passes, the plasma becomes hot as a result of which Bremsstrahlung and recombination radiations are produced. This is the stage where the X-ray signal gains maximum intensity as Fig. 4 represents largest peak at the leading edge of the profile. The maximum voltage recorded was 110 mV. The average energy, calculated is 28.6 eV. The whole signal which yields the duration of X-ray emission lasts for 32 ns (line 1 to line 2).

The main reaction of irradiation of polymers when exposed to X-rays is that creates permanent changes in their molecular weight. Increase in molecular weight means the cross-linkage and decrease in molecular weight means chain scission. Several other chemical changes are observed during the X-rays

irradiation on polymer film which is the loss of mass, decreased intensity, and formation of modified new chemical structure. The unexposed sample shows the crystalline structure and exposed to X-rays sample shows the amorphous behavior. This amorphous behavior is mainly due to the scission process and goes on increasing due to more irradiation.

### 3.1 Optical microscopy

This technique was used to investigate the morphological changes on the surface of PMMA and

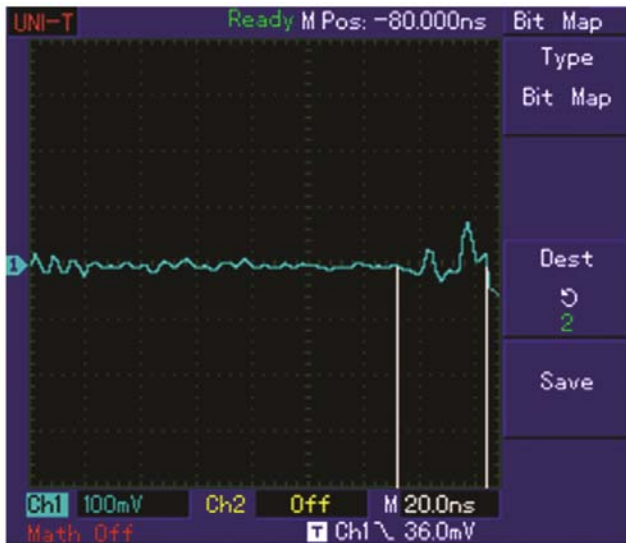

Fig. 4 — X-ray signal from Cu plasma.

PE due to irradiation of X-rays. Irradiation of X-rays on the surface of these polymers results some changes in the morphological properties.

Figure 5 represents the optical micrograph of an unexposed sample of polyethylene, which represents that there are no observable micro holes on the surface. Scratches on the unexposed sample are because our substrate material is not so fine. Figure 5(b,c) represents the optical micrograph of polyethylene at 200 magnifications, irradiated with 100 and 200 shots of Nd: YAG Laser. Holes in the above two results are showing that localized melting produced due to X-ray irradiation. Figure 5(d,e) represents the optical micrograph of polyethylene at 200 magnifications, irradiated with 300 and 400 shots of Nd: YAG Laser. These figures represent localized melting at the surface of polyethylene.

Figure 6 represents the optical micrograph of an unexposed sample of polypropylene, which represents that there are no observable micro holes on the surface. Figure 6 (b,c) represents the optical micrograph of polypropylene at 200 magnifications, irradiated with 100 and 200 shots of Nd: YAG Laser. Figures show that when X-rays are irradiated, localized melting is produced. Holes in the above two results are showing that localized melting produced due to X-ray irradiation. Figure 6 (d,e) represents the optical micrograph of polyethylene at 200 magnifications, irradiated with 300 and 400 shots of

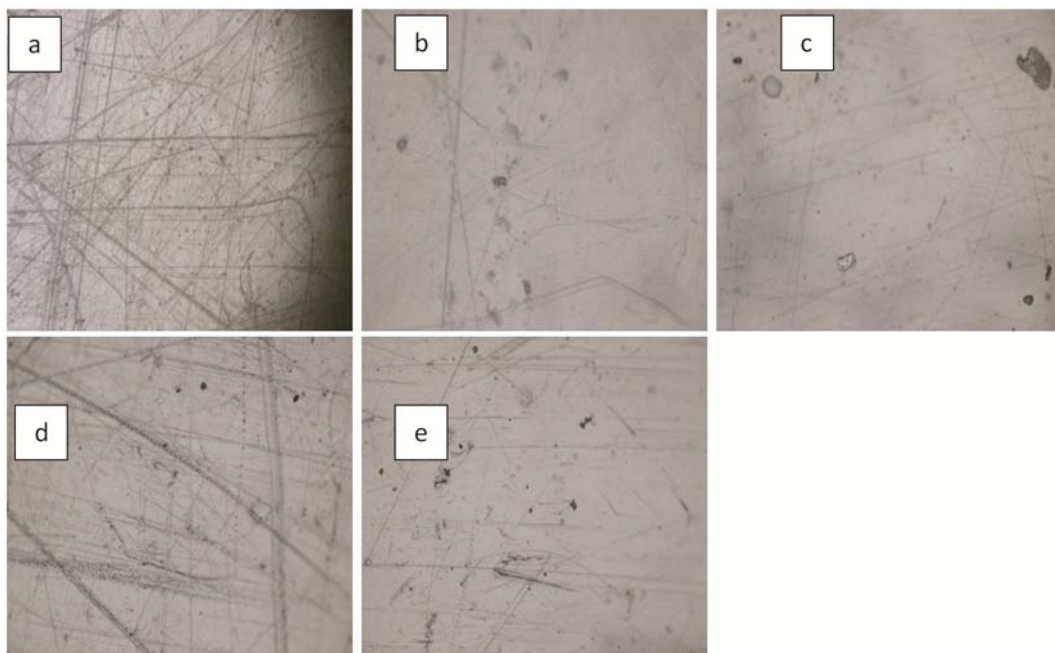

Fig. 5 – Optical micrograph of polyethylene

Nd: YAG Laser. These figures represent localized melting at the surface of polyethylene.

Above results obtained from optical microscopy of polyethylene and polypropylene are clearly representing that when radiations are focused on the polymer surface, modification of surfaces, ablation of the surface produced due to stress within the sphere which results in ablation as well as elongation of spheres. Due to this stress, cracks and breakage of bonds, at the substrate interface is produced. This stress produces intense heat in the localized region of the lattice. The temperature goes on increasing in this region, but rapidly cools down to low temperature, which makes narrow spikes and holes, responsible for serious localized radiation damage to the surface. This intensely induces the highly localized stressed area on the polymer's surface.

When the surface of polymers is exposed to X-ray fluence, depression is observed. Hydrogen is the main product of bond breaking induced by these rays. Due to the diffusion of this gas, spaces are produced for better orientation and appear as a depression on the polymer surface. The blackening spots in the results are due to burning.

Figure 5 shows the unexposed optical micrograph of polyethylene. This figure clearly describes the small size and shape of particles on the surface. When this sample is exposed to X-rays generated from Cu plasma, both the size and shape of particles ultimately

increased which has been shown in the Fig. 5(a-e). Similarly, the irradiation of X-rays on polypropylene has created much more effect on the surface than polyethylene. Figure 6(a-e) shows the size and shape change of the particles of the surface. Internal stress produces large elongation in size leading to fragmentation. This irradiation also reduces the molecular weight of polymers due to the chain scission during the interaction. Polyethylene is less affected by X-rays as compared to Polypropylene because polyethylene contains lower static charge and translucent nature.

### 3.2 Electrical properties

To investigate the electrical properties of polypropylene and polyethylene, the four point probe technique is used. The resistivity of the polymers is calculated by using the formula given below:

$$\rho = \frac{\pi}{\ln 2} t \left( \frac{V}{I} \right)$$

where  $\rho$  is the resistivity of the material;  $t$  is the thickness of material which is 12  $\mu\text{m}$  for PE and 6  $\mu\text{m}$  for PP;  $V$  is the voltage which remains the same;  $I$ , is the current applied between two parallel probes which is varied between 10 mA to 50 mA

The change in resistivity of polyethylene and polypropylene is shown in the graphs. These graphs

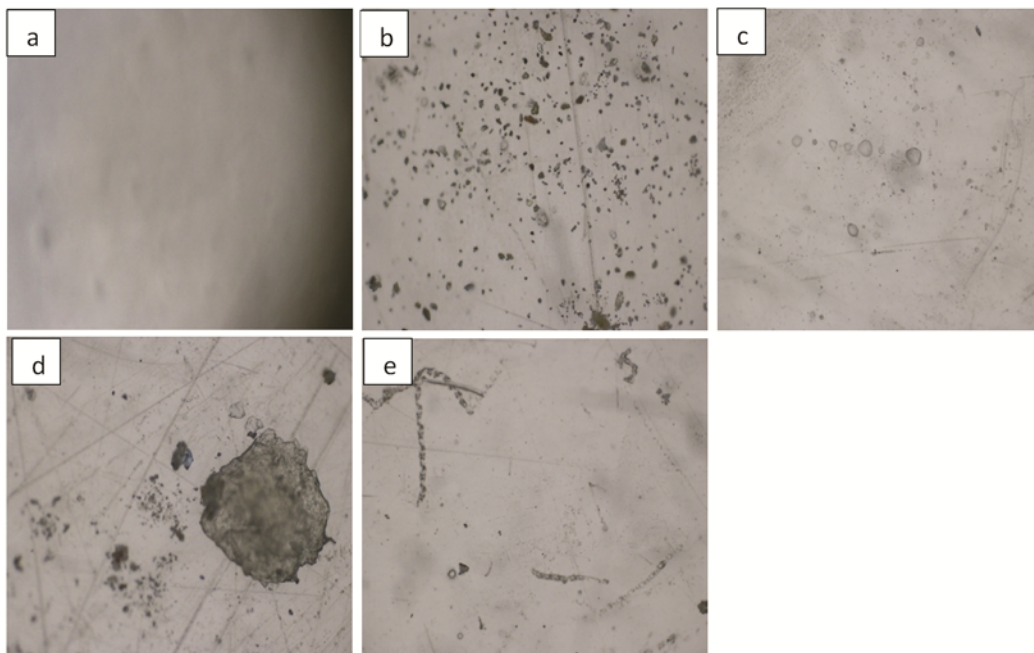

Fig. 6 — Optical micrograph of polypropylene (a) unexposed, (b) 100 shots, (c) 200 shots, (d) 300 shots and (e) 400 shots.

clearly show the decrease in the resistivity of polymers as given in Figs 7 and 8. This is because when X-ray photons from laser produced plasma are irradiated on the surface of polymers (PE and PP), it will produce very complex processes like bond breaking or new bond formation called as chain scission and cross-linking. When X-ray photon interacts with the polymer chain, it will knock out H atom from C-H bond creating free ion of hydrogen, which will combine with other H atoms to make neutral atoms of  $H_2$ , while C makes a bond with a C atom of another chain making chain scission and cross-linking, providing a path to conduct electricity. Due to this reason when X-rays are focused on the polymer surface, the resistivity of polymer decreases

and conductivity increases. Polypropylene becomes less conductive as compared to polyethylene because of lower static charges against the repulsion of high energy charged particle and translucent nature of material. The conductivity of polyethylene has been increased to 97.9% and of Polypropylene; it has been increased to 95%.

The softening or hardening of a material defines the effect of irradiation. Although the energy of X-rays and ions is same but both interact with material differently because both polymers modified have different structure and chemical bonding. Ions damage more than X-rays at surface because their larger size while X-rays can penetrate in depth at the surface of the material having much smaller size.

### Resistivity of Polyethylene

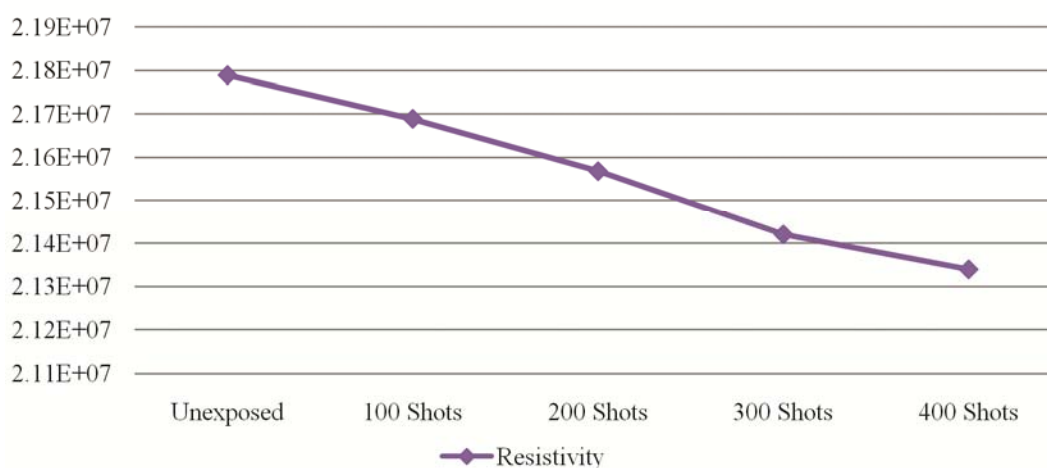

Fig. 7 — Graph of resistivity of polyethylene.

### Resistivity of Polypropylene

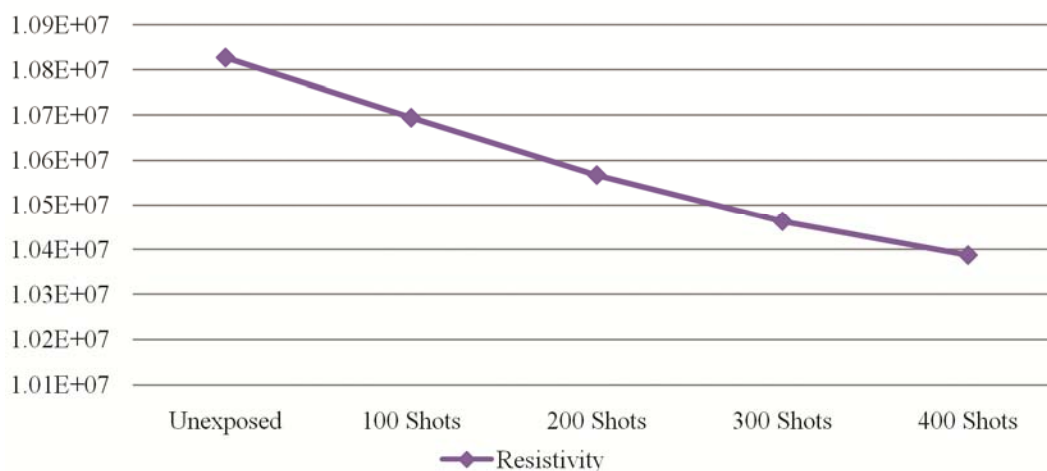

Fig. 8 — Graph of resistivity of polypropylene.

#### 4 Conclusions

In the present experimental work, laser produced plasma X-ray interaction with the surface of two different polymers (Polyethylene & Polypropylene) studied when Nd: YAG laser with energy of 10 mJ and of wavelength 1064 nm is focused on Cu metal target. The energy of X-rays emitted from Cu plasma has been calculated and effect on the surface of polymers has been analyzed by using a technique of optical micrography and conductivity by four-point probe method. It is concluded from time resolved signals of X-rays that energy of X-rays varies as the numbers of shots of laser pulse are changed. As the laser shots are increased, the energy of X-rays is changed. The average energy calculated was 28.6 eV. Morphology of material surface changes strongly as the numbers of shots of the laser are increased. X-rays emitted from laser produced plasma produce holes, chains and also localized melting at the surface of polymer substrates. Scratches on the surface of the substrate polymers are also produced somewhere. An observable result that has been deduced from the above results is that surface modification is different for both the substrates when irradiated with the same number of shots of laser energy. It has been observed that irradiation of X-rays from laser produced plasma produce changes in the bonding structure of polymers as it produces cross-linking and chain-scissioning which are highly responsible for breakage or formation of a bond. A similar type of a result is deduced from four point probe method that the resistivity of polymers is decreased. It is due to the breakage of the H-C bond. As it is clear from the results that the resistivity of polypropylene is decreased more as compared to the polyethylene. It can be because of the simple structure of polypropylene as compared to polyethylene.

#### References

- Vijayalakshmi K A, Mekala M, Yogannad C P & Naaneetha K P, *Int J Polym Sci*, 426057 (2011) 1.
- Shenton M J & Stevens G C, *J Phys D*, 34 (2001) 2761.
- Liston E M, Martinu L & Wertheimer M R, *J Adhesion Sci Technol*, 7 (1993) 1091.
- Nathawat R, Kumar A, Kulshrestha V, Vijay Y K, Kobayashi T & Kanjilal D, *Nucl Instr Meth Phys Res B*, 21 (2008) 4749.
- Keil M, Rastomjee C S & Rajagopal A, *Appl Surf Sci*, 125 (1998) 273.
- Kitova S, Minchev M & Danev G, *J Optoelectron Adv Mater*, 7 (2005) 2607.
- Vargo T G, Gardella J A & Salvati L, *J Polym Sci Part A*, 27 (1989) 1267.
- Bhat N V, Upadhyay D J, Deshmukh R R & Gupta S K, *J Phys Chem B*, 107 (2003) 4550.
- Bilal M T, Rafique M, Rafique M S, Awan T I & Nabi G, *Indian J Pure Appl Phys*, 55 (2017) 145.
- Ardelean H, Petit S, Laurens P, Marcus P & Khonsari A F, *Appl Surf Sci*, 243 (2005) 304.
- Cutroneo, Malinsky P, Mackova A, Matousek J, Torrisi L, Slepicka P & Ullschmied J, *Nucl Instr Meth Phys Res B*, 365 (2015) 384.
- Mohanty S R, Neog N K, Nayak B B, Acharya B S, Lee P, Tan T L & Rawat R S, *Nucl Instr Meth Phys Res B*, 243 (2006) 113.
- Ahmed R, Rafique M S, Tahir B M & Malik H, *Laser Part Beams*, 32 (2014) 261.
- Sinha D, Sahoo K L, Sinha U B, Swu T, Chemseddine A & Fink D, *Radiat Eff Defects Solids*, 159 (2004) 587.
- Yasuhiko N, Atsushi S & Hirozumi A, *J Surf Sci Soc Jpn*, 20 (1999) 173.
- Clough R L, *Nucl Instr Meth Phys Res B*, 185 (2001) 8.
- Fazeli R, *Phys Lett A*, 381 (2017) 467.
- Faenov A, Pkuz T, Magunov A, Batani D, Lucchini G, Canova F & Piselli M, *Laser Part Beams*, 22 (2004) 273.
- Iqbal S, Rafique S M, Anjum S, Hayat A & Iqbal N, *Appl Surf Sci*, 259 (2012) 853.
- Keil M, Rastomjee C S & Rajagopal A, *Appl Surf Sci*, 125 (1998) 273.
- Sprang N, Theirich D & Engemann J, *Surf Coat Technol*, 74 (1995) 689.
- Ma Y, Chen C T, Meigs G, Randall K & Sette F, *Phys Rev A*, 44 (1991) 2007.
- Fuchs B, Schlenkrich F, Seyffarth S, Meschede A, Rotzoll R, Vana P, Grobmann P, Mann K & Krebs H, *Appl Phys A*, 98 (2009) 711.
- Rana D S, Chaturvedi D K & Quamara J K, *J Mater Eng Perform*, 20 (2010) 276.
- Sava F, Cristescu R, Socol G, Radvan R, Savastru R & Savastru D, *J Optoelectron Adv Mater*, 4 (2002) 965.
- Kobayashi T, Miyamoto S, Ikeda T, Kojima M T, Ogiwara K & Yamazaki Y, *Nucl Instr Meth Phys Res B*, 272 (2012) 405.
- Mark J E, *Polymer data handbook*, 2<sup>nd</sup> Edn, (Oxford University Press), 1999.
- Sarantopoulou E, Kova J, Kollia Z, Raptis I, Kobe S & Cefalas A C, *Surf Inter Anal*, 40 (2008) 400.
- Kaariainen T O, Cameron D C & Tanttari M, *Plasma Process Polym*, 6 (2009) 631.