



Development of vacuum compatible, multi-mode operation light source

Anshul Kumar Porwal

Space Application centre (SAC), ISRO, Ahmedabad 380 015, India

Received 3 January 2020; accepted 2 June 2020

Light sources are used extensively at various stages of development and characterization of an electro-optical (EO) payload like Cartosat, HySIS, Microsat etc. These sources are required to characterize many critical parameters of EO payload like photo response non uniformity (PRNU), noise performance, saturation radiance etc. Currently integrating sphere with quartz tungsten halogen (QTH) lamp is widely used for payload characterization. These lamp sources generally operate in continuous mode in clean room environment and thermo-vacuum. In case of high resolution payloads, time-delay and integration (TDI) detectors are used to improve signal collection. For characterization and testing of such payloads multi-mode (pulsed and continuous) light source (switching at kHz rate in synchronization with payload electronics) with specific spectral range is required. Pulse mode operation requirement cannot be met using QTH lamps. To cater to such need a LED based indigenous source has been developed. This paper delineates circuit design and implementation of driver and characteristics of the source is also discussed. Proposed source is capable to synchronize and operate in multi-mode with external clock pulse with high achieved linearity (>99%) and high stability (>99%) in vacuum condition.

Keywords: Light source, LED, Constant current mode, Pulse mode, Continuous mode, Vacuum compatibility

1 Introduction

EO systems can generally be considered as a transducer which converts electromagnetic radiation into electrical signal to convey information of the target¹. It is an assembly of various components like optical, mechanical, electronics and sensor systems^{2,3} which are integrated such that the image formed by an optical system at its focus is sampled by the detector head assembly (DHA) and subsequently signal is processed, digitized, encoded and forwarded to transmitter of the satellite. Block diagram of EO payload is shown in Fig. 1.

EO payload is characterized for optical, spectral, radiometric⁴ response under the different environmental conditions to simulate the actual space conditions. These environmental tests reveal the criticality/deviations in performance with respect to expected. These tests also ensure the system performance of complete chain due to assembly, integration and electrical interfacing with different subsystems. EO payloads are tested in simulated space condition (thermo-vacuum chamber) to characterize its performance over a specified temperature range and vacuum condition.

Design requirements to develop a light source that is versatile in operation, covers broad spectral range (with possibility of tunability and adjustability), pulse

mode operation for TDI detector⁵ and vacuum compatibility. Following are the considerations for development of light source:

- (i) Design should be vacuum compatible.
- (ii) Selection of source that caters to wide spectral response with scope of adjustability.
- (iii) It should be portable, capable to operate in continuous mode and pulse mode for testing of area array mode of operation (Matrix mode⁵) of TDI detector.
- (iv) It should be compatible with external input (either inverting or non-inverting) for synchronous operation with payload.

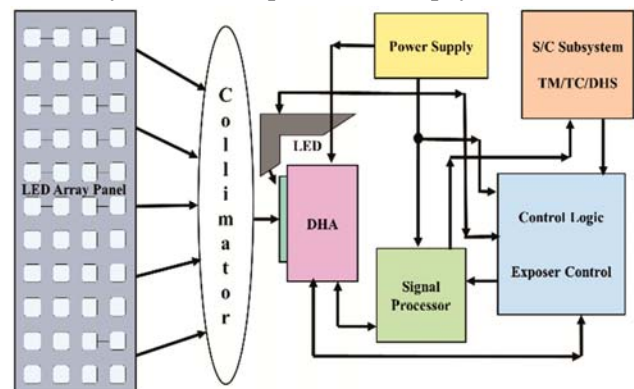

Fig. 1 — Block diagram of a typical EO payload (TM is Telemetry, TC is Tele command, DHS is Data Handling System, S/C is Space Craft).

- (v) For safe operation of driver and high power components incorporation of thermal management system in design;

Various types of light sources⁶ are available viz. incandescent lamp, compact fluorescent lamp, LED, laser etc. These are suitable for certain applications depending upon their characteristics as discussed in Table 1. LED has advantages over other sources⁷ in terms of higher efficiency, long life and fast response time. Considering these advantages, LED based light source has been selected.

This paper presents, development and testing of a vacuum compatible LED based illumination source. Which facilitates testing of a sub-system or integrated payload in thermo-vacuum and ambient conditions. Developed source also caters to requirements posed for characterization of TDI detectors based payloads.

2 Design of Illumination source for EO Payload

According to EO payload characterization requirement, high intensity light source with intensity

control and multi-mode operation capability is essential. The design of illumination source requires the following:

- (i) LED based Illumination source (EO converter)
- (ii) LED Driver Unit (LDU)
- (iii) Input power unit (PU)
- (iv) Thermal system (active/passive)
- (v) Mechanical housing

Block diagram of LED based illumination source is shown in Fig. 2. Illumination source should have high efficiency, fast response time, low power consumption, high intensity and thermo-vacuum compatibility. These requirements were met by same type numerous high power chip LEDs. Selected high power chip is shown in Fig. 3.

Forty-four LEDs were incorporated to enhance light intensity. These were arranged in 11x4 pattern in order to cater to rectangular field of view. To ensure

Table 1 — Comparison of various light sources.

Features	Incandescent	Compact Fluorescent	LED	Laser
Efficiency (%)	Very less	> Incandescent Lamp	more efficient as compared to above lamp	>65
Wave length (um)	0.3-2.5	0.4-.7	0.35 – 1.6	0.193-10.600
Switching time	Few seconds	Few mili-seconds	Few nano-seconds	Few nano-seconds
Size	Very large	Smaller than incandescent but larger than LED	Very Small	Very Small
Life (hours)	~ 1500 to ~2000	~ 6000 to ~15000	~50000 to ~100000	~70000

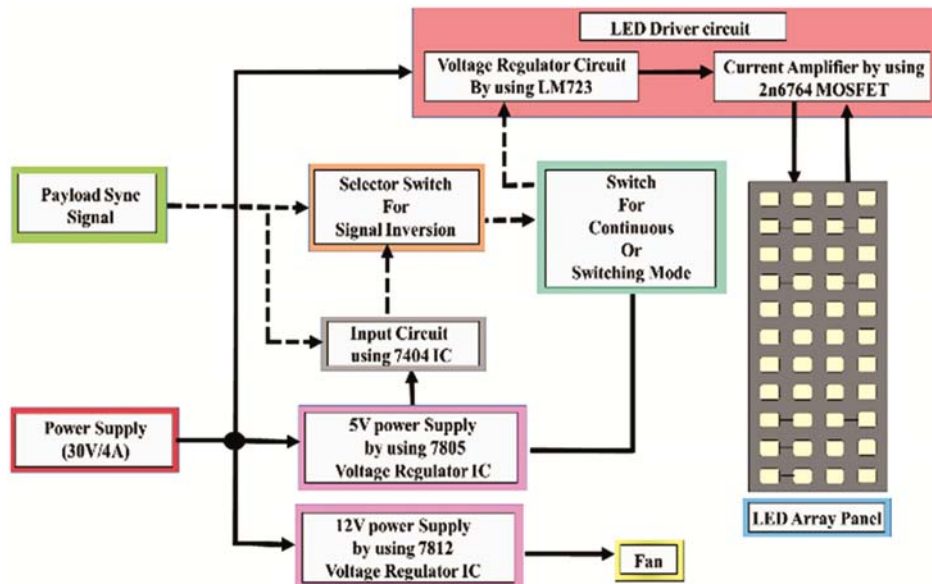

Fig. 2 — Functional block diagram of LED based illumination source.

optimal design w.r.t. line voltage and current, two LEDs are connected in series and such twenty-two sets are connected in parallel. The LEDs are mounted on an aluminium metal plate with thermal glue (EC2216) to allow fast heat transfer⁶ from LED to aluminium metal plate. The metal plate acts as a heat sink and able to reduce the LED temperature thereby preventing thermal damage of LEDs⁹. Developed Illumination test setup board is shown in Fig. 4.

For operation of Illumination test setup, drive circuit has been used. It is called LED driver unit (LDU). LDU drives the LEDs in pulsed/continuous mode with constant current. LM723 based driver circuit followed by high current MOSFET amplifier has been designed to drive the LED in constant current mode to ensure constant intensity. 2N6764 Power MOSFET is selected to meet high current demand of 4A. LM723 has been used to regulate current flowing through LEDs and also enabling pulse mode of operation. The circuit is shown in Fig. 5.

Required LED current is configured by resistor divider network at non-inverting input using internal reference voltage (7.2V) of LM723. Resistor R_{2a} defines the current flowing through LEDs.

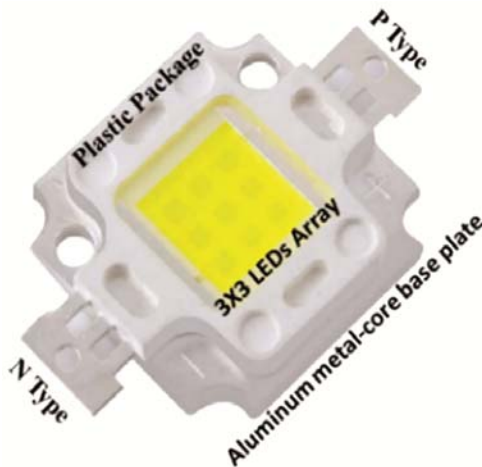

Fig. 3 — High power chip LED.
(Part No. LEDE- P10B-d-White with operating voltage of 10V and response time <100ns [8])



Fig. 4 — Illumination test setup board.

$$V_k = \frac{7.2}{R_1 + R_2} * R_2$$

For V_k = 1 V, R₁ = 6.2 kΩ & R₂ = 1 kΩ
For 4A current through LEDs,

$$R_{2a} = \frac{V_k}{1} = \frac{1V}{4A} = 0.25\Omega$$

Power dissipation and Stress of resistor, IC LM723 and MOSFET 2N6764 is as follows:

- (i) Power dissipation across R_{2a},
 $V * I = 1V * 4A = 4W$
- (ii) Power dissipation across IC LM723,
 $(V_{cc} - V_{out}) * I_o = (30 - 26.6)V * 1.38mA$
 $= 4.6mW$
- (iii) Power dissipation across MOSFET,
 $V_{DS} * I_D = (28.8 - 22.6)V * 4A = 21.93W$

Stress computation for above mentioned components are given in Table 2.

Synchronous pulse signal (TTL/LVTTL) from the payload is fed into input pin (no. 2) of 723 IC through a Dual Pole Single Throw (DPST) switch (selecting direct or inverted input using 74LS404 IC) to synchronize the light output to payload operation. Another DPST switch is introduced to drive LED in continuous mode if required. Developed LED drive unit is shown in Fig. 6.

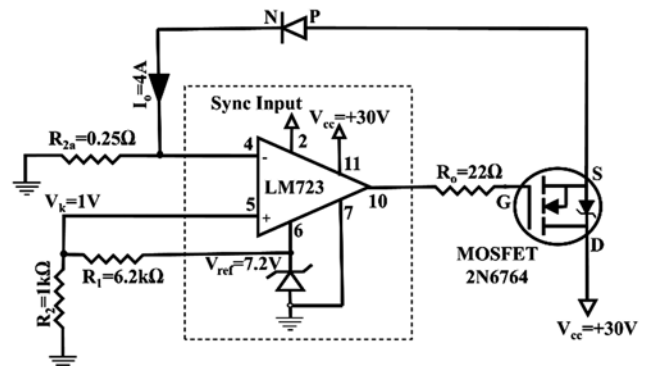

Fig. 5 — Circuit diagram.

Table 2 — Power computation.

Component	Power (W)		Stress
	Rated	Actual dissipation	
LM723	0.9 ¹⁰	0.0047	0.005
MOSFET (2N6764)	150 ¹¹	21.93	0.14
Resistor R _{2a}	20	4	0.2

The circuit is driven through a DC power supply at 30 V. Required lower voltages (+5.0 & +12.0V) for 74LS04 and cooling fan are derived from 30V input using voltage regulator ICs (7805 & 7812). Since high power dissipation is estimated in MOSFET, thus force cooling (fan based) is implemented to maintain temperature of MOSFET within safe limits.

3 Measurement and Results

Selected LED and Assembled LED source has been tested individually with external power supply. Driver electronics was tested with high power dummy load prior to integration with actual LED source.

After successful stand-alone testing of power supply, LEDs and driver electronics. The integrated test of all three has been performed and following measurements were carried out.

3.1 Measurement of LED

The V/I characteristics curve shows the relation between LED voltage and current. Hence to verify LED characteristics test has been performed using voltage and current digital multi meter. Figure 7 gives measured V/I characteristics of the LED.

The developed light source caters to wide visible spectral range from 400 nm to 700 nm. Spectrum has been measured through spectrometer (SR3500-Spectral Evolution) with help of a transmissive diffuser. Figure 8 shows scheme for spectrum measurement and Fig. 9 shows measured spectrum of the selected LED.

TDI is a special image acquisition method which realizes both high-speed and high sensitivity. Certain characteristics of TDI detector can be only tested with light source being operated synchronously with detector operation. To evaluate functionality of source in pulse mode, TTL clock through function generator ($V_{pp}=1.5$ V, offset=750 mV, Period = 6 to 7 ms with varying duty cycle) was fed into driver circuit. Measured LED response time was less than 6 μ s. Test setup for pulse mode measurement is shown in Fig. 10.

LEDs were tested in thermo-vacuum without driver circuit to verify and establish its vacuum compatibility and operating range of temperature.

Figure 11 shows the LEDs under test condition inside the thermo-vacuum chamber. Five LEDs were subjected to the following tests:

- (i) Cold storage at -30° for 12 hours.
- (ii) Hot storage at $+80^{\circ}$ for 12 hours.
- (iii) Thermo-vacuum cycle: -10° to $+50^{\circ}$, 30 min. operation, 3 cycles.
- (iv) Outgassing test

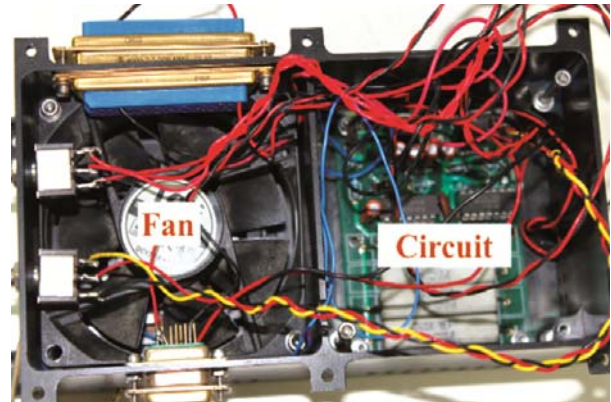

Fig. 6 — LED driver unit.

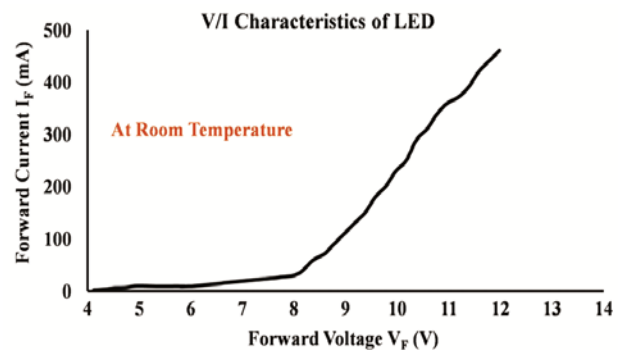

Fig. 7 — V-I characteristics of the LED.

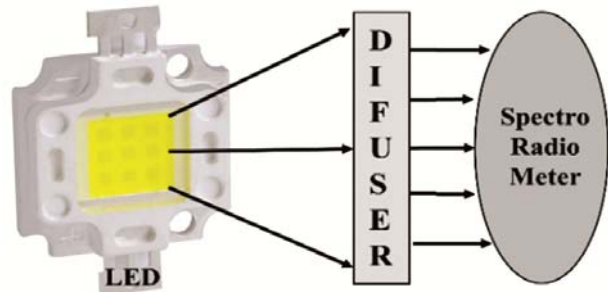

Fig. 8 — Scheme for spectrum measurement of LED.

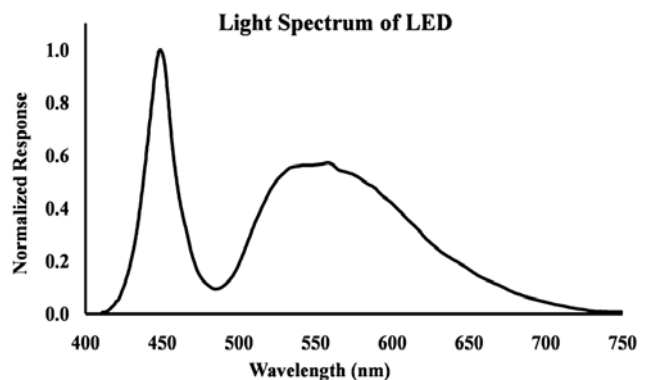

Fig. 9 — Measured spectrum of LED.

Thermo-vacuum temperature cycle w.r.t. time is shown in Fig. 12.

It was ensured that pressure inside thermo-vacuum chamber was maintained better than 10^{-5} mbar throughout the testing.

These LEDs were energized with +10 V and 200 mA power supply. LED forward voltages were monitored before and after environmental tests.

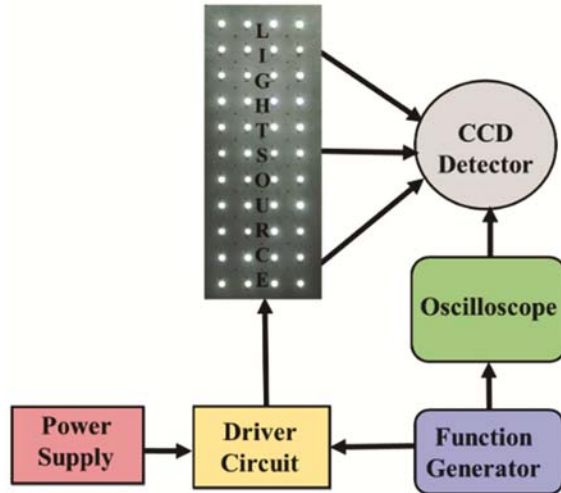

Fig. 10 — Pulse mode measurement.

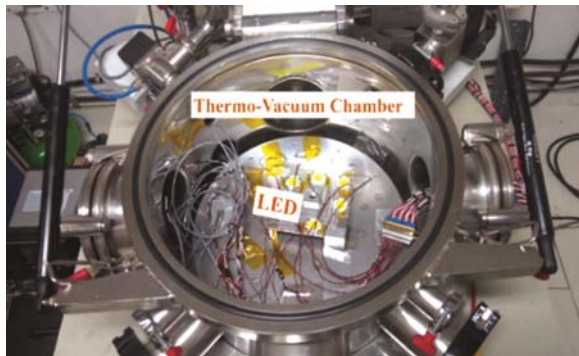

Fig. 11 — Thermo-vacuum testing setup.

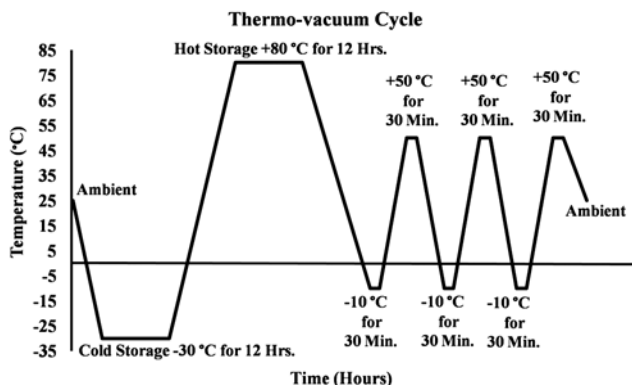

Fig. 12 — Thermo-vacuum cycle.

Measured voltage and drift w.r.t. ambient are given in Table 3.

Total mass loss (TML) and collected volatile condensable materials (CVCM) was also measured to ensure outgassing of material. These measured below in Table 4.

TML and CVCM of polymer lens material was marginally higher but it is acceptable because light source will be operated in vacuum chamber for limited hours only. Hence, the above tests established vacuum compatibility of LEDs and the developed source.

3.2 Measurement of LED light source

Output transfer characteristics of the source were measured using a Lux Meter (HTC LX-101A). Lux meter was placed in front of the source. The applied LED forward voltage was varied through power supply and Lux meter readings were recorded. Test setup is shown in Fig. 13 and measured intensity as function of input current is shown in Fig. 14.

Cartosat panchromatic detector was illuminated using the developed source with varying level of



Fig. 13 — Linearity measurement by Lux meter setup.

Table 3 — Summary of environmental test.

LED No.	Initial (V)	Post storage (V)	Drift (%)	Post Thermo-Vacuum (V)	Drift (%)
LED1	9.89	9.96	1%	10.11	1%
LED2	9.99	10.04	0%	10.11	1%
LED3	9.99	9.97	0%	9.93	-1%
LED4	9.82	9.84	0%	10.18	4%
LED5	9.52	9.95	4%	10.50	10%

Table 4 — Summary of out gassing test.

Material	% TML	%CVCM
Expected as per ASTM E-595	<=1%	<=0.1%
Polymer Lens	1.69	0.153
Plastic Package	0.836	0.0003

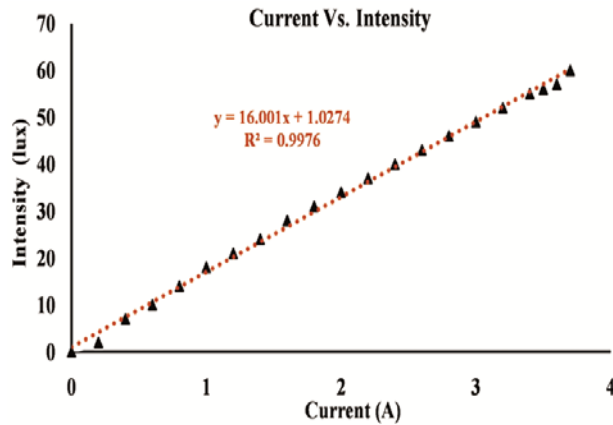

Fig. 14 — Characteristics of current versus intensity.

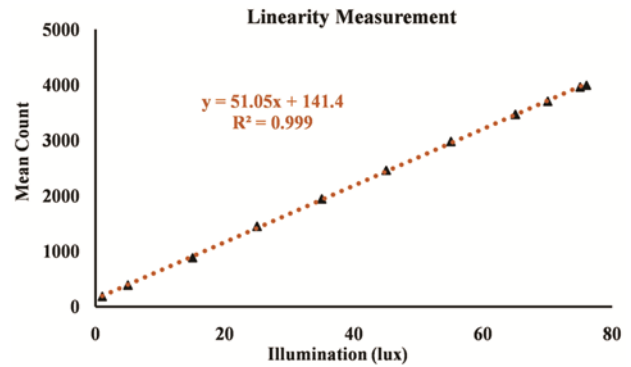

Fig. 16 — Detector response.



Fig. 15 — Linearity measurement by detector setup.



Fig. 17 — Stability measurement.

intensity. Intensity was measured simultaneously with a Lux meter as shown in Fig. 15. The detector response w.r.t. to incident light intensity has been measured as shown in Fig. 16. Detector noise behaviour matched with photon noise distribution, validating the stability of the source and thus its usability for radiometric measurement.

In order to establish stable operation of the developed light source, it was operated continuously for half an hour and its output intensity was recorded by a Flux meter placed in front at a distance of 2 meters. Figure 17 shows the LEDs under stability test.

Figure 18 shows the output of Flux meter over the duration. Intensity of Light source is stable within 99.79%.

Light source was also operated in thermo-vacuum chamber for 5 hours at $5e^{-5}$ mbar vacuum and temperature was varied from 15 °C to 35 °C. Source performed satisfactorily with input current variation of only 0.2A at 4A (5%), which is within limit.

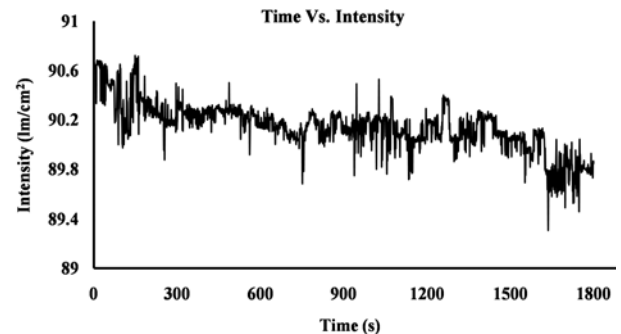

Fig. 18 — Stability measurement by Flux meter.

4 Conclusions

A portable, custom built, indigenous and versatile light source for testing of EO payloads for sensor/TDI sensors has been designed and developed. It meets all the design requirements with various multi-mode operation. The source is capable of operating in thermo-vacuum condition as well. Various tests were performed to characterize the developed source. The designed source was successfully operated at high pulse rate. Developed source achieved Linearity of better than >99% and stability of better than 99%. This light source can be used in vacuum environment as well and useful for EO payload characterization.

Acknowledgement

The author would like to thank Director, SAC (Shri D K Das), Deputy Director, SEDA (Shri S S Sarkar) and Group Director, EOSDIG (Shri H K Dave) and former Head, SSD (Shri Manish A Saxena) for their kind support and encouragement to carry out this work. I am thankful to Sci./Engr. Dr.s Harish Seth, Shri Amarnath and Shri Nitesh Thapa. I also thank Sci./Engr. Shri Rishi Kaushik and QA team for qualifying LEDs for vacuum operation. I thank SAC reviewers for their valuable feedback to improve quality of this work. I also thank all the colleagues, friends and my family for their contribution and support.

References

- 1 Wyatt C L, *Electro-Optical System Design for Information Processing*, McGraw-Hill, Utah State University, 1991.. https://digitalcommons.usu.edu/usufaculty_monographs/115, 1991.
- 2 Willers C J, *Electro-Optical System Analysis and Design: A Radiometry Perspective*, *SPIE*, 2013, *ch1pg17*] <https://doi.org/10.1117/3.1001964>.
- 3 Committee of Earth Studies, *The Role of Small Satellites in NASA and NOAA Earth Observation Programs*, (Washington, D.C), 2000, *ch3pg22*].
- 4 Platonov V N, Eliseev V V, Chulkin A D, Vyssogorets M V & Majumdar S, *Proc SPIE*, 91 (1992) 1539. <https://doi.org/10.1117/12.50560>.
- 5 Sarkar A, Sharma B N, Saxena M, Thapa N, Kumar A, Dave H K & Sarkar S S, *Appl Remote Sens*, (2018) <http://10.1117/1.JRS.12.034003>.
- 6 Schubert E F & Kim J K, *Science*, 308 (2005) 1274. <http://10.1126/science.1108712>,
- 7 Bepalov N N, Kapitonov S S, Ilyin M V, Zorkin A V & Volkov A G, *IEEE Conference of Russian Young Researchers in Electrical and Electronic Engineering*, El Con Rus, (2018). <https://10.1109/EIConRus.2018.8317434>.
- 8 Data sheet of 10W Epistar 35mil Chip High Power LED, <http://www.kosmodrom.com.ua/pdf/APRL-10W.pdf>, 2012, Edition: V1.0
- 9 Kapitonov S S, Kapitonova A V & Grigorovich S Y, Development of thermal LED Model, *J Fundament Appl Sci*, <http://dx.doi.org/10.4314/jfas.v9i7s.71>, 9 (2017).
- 10 Data sheet of Texas Instruments LM723 IC, SNVS765C, JUNE 1999–REVISED APRIL 2013] <https://www.ti.com/lit/ds/symlink/lm732.pdf>.
- 11 Data sheet of MOSFET (2N6764), PD- 90337H, sep. 2019] <http://www.irf.com/productinfo/datasheets/data/jantx2n6764.pdf>.